

**ADVERTISEMENT FOR COMPETITIVE SEALED PROPOSALS
RFP 2025-003**

Pursuant to chapter 2269 of the Texas Government Code, the City of Burnet seeks competitive sealed proposals, in envelopes addressed to the City of Burnet, 1001 Buchanan Drive Suite 4, Burnet, Texas 78611, for the **2025 Inks Raw Pump Maintenance & Replacement, PID: RFP 2025-003**, in the City of Burnet, Texas, which will be received at the above-mentioned address until **11:00 A.M., April 3rd, 2025**. At such time the proposals will be publicly opened, and the name of each offeror and the corresponding price component of each proposal will be read aloud. Bids will be opened in-person in the same location as the bid opening.

Proposals must be submitted in sealed envelopes and marked "2025 Inks Raw Pump Maintenance & Replacement , PID: RFP 2025-003."

The Contract Documents and Specifications are available at the City of Burnet. Questions and requests for additional information shall be sent by email to: ebelaj@cityofburnet.com. For this project, all bidders will be **required** to accept Addenda and other pertinent information by email, as well as provide written acknowledgement of Addenda as prescribed in the Instructions to Bidders. **No questions or requests for additional information will be accepted later than 5:00 p.m., April 1, 2025.**

Bid packages will be available at the City of Burnet City Hall, located at 1001 Buchanan Drive Suite 4, Burnet, Texas 78611, Monday through Friday, 8:00 a.m. to 5:00 p.m. for viewing only. Project general conditions and standard specifications manual can be found on the City's website at www.cityofburnet.com

An optional pre-bid conference will be held on March 27, 2025, at 11:00 AM via web meeting utilizing Microsoft Teams at the following: Teams Meeting ID: 229 953 773 665 Passcode: SC9BA2qB

After contract is awarded, the contractor will be required to furnish insurance (Texas affiliate), and payment bond. A certified check or bank draft payable to the City of Burnet may be submitted in lieu of the Bid Bond.

The City of reserves the right to waive any irregularity, informality, or nonconformity in the submission of a proposal or to disqualify from consideration any offeror who fails to submit requisite information. The City reserves the right to postpone proposal submission deadlines or cancel this solicitation at any time prior to execution of the contract contemplated by this RFP.

No bidder may withdraw his bid within ninety (90) days after the actual date of opening thereof and pricing submitted with the proposal must be valid for 90 days following the date of opening listed above.

If you have any questions, please e-mail Eric Belaj at: ebelaj@cityofburnet.com.

City of Burnet, Texas
Eric Belaj, City Engineer

Newspaper ad published twice:

Wednesday March 12th, 2025
Wednesday March 19th, 2025

CITY HAS COPY OF AFFIDAVIT OF PUBLICATION

BID SHORT FORM

Project name: **2025 Inks Raw Pump Maintenance & Replacement, PID: RFP 2025-003**

Construction Description: Provide a proposal along with the items laid out in the Scope of Work attached hereto.

We, the undersigned, propose to furnish all materials, labor, and equipment for the completion of this project and guarantee that if we are awarded the bid, we will furnish the goods in accordance with the attached specification. THIS FORM MAY BE COPIED

TOTAL PROPOSAL PRICE: See Attached Quote

By submitting this proposal, the submitter understands that they must enter into an agreement with the City for the award of this contract. The City may enter into a contract that restricts the total contract amount, total contract time, or number of accounts served.

EXCEPTIONS:

BID PRICE IS GUARANTEED FOR 90 (NINETY) DAYS AFTER BID OPENING BY CITY

MINIMUM BID SPECIFICATIONS BID FORM: Construction of the project title noted above for the City of Burnet.

We, the undersigned, propose to furnish the item listed below and guarantee that if we are awarded the bid, we will furnish the goods in accordance with the attached documents and the City's Technical Construction Standard Manual.

Authorized Signature Name of Firm: _____
Signature Date

Printed Name of Signee: _____

Firm Address: _____
Street No & Suite, City, State, Zip Code

Telephone Number: _____, Fax Number: _____

All Bids shall be submitted on forms supplied by the City of Burnet (City).

Bid documents shall be submitted via mail. An electronic copy of the bid can be submitted in addition to a hard copy via postal mail addressed to: Burnet City Hall, Office of Kelly Dix, 001 Buchanan Dr, Suite 4, Burnet TX. It is the sole responsibility of the bidder to see that his bid is received on time.

BIDDERS (SUBMITTERS) QUALIFICATIONS:

The City of BURNET shall have the right to take such steps as it deems necessary to determine the ability of the bidder, to perform his obligations under the Contract and the bidder shall furnish the City of BURNET all such information and data for this purpose, as the City of BURNET may request it. The right is reserved to reject any bid where an investigation of the available evidence or information does not satisfy the City of Burnet, whereas the bidder is qualified to carry out properly the terms of the contract.

The proposed bids are to include a list of similar projects the firm has completed in the last 5-years as shown in the proposal instructions. That list to include a one sentence description, owner contact name and phone number. Bidders will be required to fill out State of Texas Conflict of Interest Questionnaire and form TGC 2270.

AWARD OF CONTRACT: REJECTION OF BIDS:

The Contract will be awarded to the responsible bidder submitting the best value evaluated bid complying with the specifications. The award of the Contract will be based upon consideration of not only cost, but also experience with similar projects, references and background search, staffing, equipment, present workload, demonstrated ability to meet schedules, and other criteria as allowed by the Local Government Code Section 2269. The City of BURNET will give weight to each of the above selected criterion based upon the relative importance of each to this project. The City of Burnet, however, reserves the right to reject any and all bids and to waive any formality in bids received whenever such rejection or waiver is in the City of BURNET's interest. The Bidder to whom the award is made will be notified at the earliest possible. Please see proposal instructions for further guidance.

PROPOSAL INSTRUCTIONS

Project supplements to general conditions and standard specifications manual can be found on the City's website at www.cityofburnet.com.

1. PROJECT

Objective of Request for Competitive Sealed Bids process is to competitively procure services with a qualified contractor whose Proposal provides best value for Owner (City of Burnet) for the project description below:

2025 Inks Raw Pump Maintenance & Replacement, PID: RFP 2025-003, in the City of Burnet, Tx.

Base Bid: Replace Inks Lake Raw pump and motor noted below. Contractor to provide all materials, manpower, and equipment needed. Bidders are strongly encouraged to visit the site. Contractor may provide a contingency amount and revise the quote after inspection for any of the alternates. Contractor may provide a contingency amount and revise the quote after inspection. Quotes below are meant to be turn-key for tear-down and new install, to inspection and delivery. If any items herein are believed to be missing or misleading, the bidder must clarify in the bid or seek prior to bid guidance.

Quote 1: *Below is the quote description to tune up Pump/motor for raw well #1:*

1. *Remove old pump and motor and ready it for maintenance.*
2. *Remove, disassemble, and inspect Well 1 Pump and Motor.*
3. *Tune-up Motor and pump, replace bearings, seals, and other routine maintenance, and repaint.*
4. *Prepare Properly Wrap Pump & Motor for storage, deliver to City at a designated location. Motor to be ready for plug-in.*
5. *Generate PMG repair report.*

Quote 2:

1. *Provide Pump Curve data. Must match existing curve as attached below.*
2. *Install new 75-hp 3/0 460V Motor and Pump*
3. *Install new 2000 GPM at 106' TDH 10" pump*
4. *Repaint discharge head and install*
5. *Anchor with rust resistant bolts and seals*
6. *New Wiring, clamps, and associated components*
7. *Stainless clamps as needed*
8. *Install new Pump and Motor, and startup procedures.*

All components must have 1-year parts and labor warranty.

The City's pre-approved pump is a SimFlo SM-14LL Submersible Pump along with Pleuger MI10-490-4, 10", 75HP 3/0, 460V, 1750 RPM Submersible Motor. The City prefers matching brand of pump/motor at the adjacent raw pump matching descriptions above for ease of maintenance and part availability. The pre-approved material may not have widespread availability. As such, respondent who cannot provide a price for the pre-approved material shall provide alternate material pricing. Alternate/as-equal materials should meet or exceed the capabilities of the pre-approved material in performance, maintenance period, durability, and other factors. Proposals with alternate material pricing should include submittals to demonstrate compliance with the specifications.

The successful bidder shall furnish all materials, labor, tools, public safety equipment, and incidentals necessary to complete this project. Project must be complete in the months December-May. Each project item shall be complete in one day, within the same week:

1. *Tear down in one day.*
2. *Reassembly within the next day.*
3. *Schedule work Monday to Thursday only.*

Existing Raw Pump Curve:

Pump:			Fluid:		
Size:	SM14LL (stages: 2)	Dimensions:	Name:	Water	
Type:	VERTTURBINE	Suction:	SG:	1	Vapor Pressure:
Synch Speed:	1800 rpm	Discharge:	Density:	62.4 lb/ft ³	0.256 psi a
Dia:	11.2 in	Vertical Turbine:	Viscosity:	1.1 cP	Atm Pressure:
Curve:	SM14LL.03.T.4646.0323	Eye Area:	Temperature:	60 °F	14.7 psi a
Impeller:	SM14LL	Bowl Size:	Pump Limits:		
Specific Speeds:	Ns: 2969	Max Lateral:	Temperature:	---	Sphere Size:
	Nss: 9516	Thrust K Factor:	Wkg Pressure:	869 psi g	1.44 in
					Power:
					887 hp
Search Criteria:			Motor:		
Flow:	2000 US gpm	Near Miss:	Standard:	US	Size:
Head:	106 ft	Static Head:	Enclosure:	TYPE 1	Speed:
			Frame:	---	1800 rpm
			Sizing Criteria:	Max Power on Design Curve	

Pump Selection Warnings:
The pump's head at the design flow rate is below the design point head value.

--- Duty Point ---	
Flow:	1999 US gpm
Head:	106 ft
Eff:	75.7%
Power:	70.6 hp
NPSHr:	17.7 ft
Speed:	1750 rpm
--- Design Curve ---	
Shutoff Head:	258 ft
Shutoff dP:	112 psi
Min Flow:	607 US gpm
BEP:	79.2% @ 1733 US gpm
NOL Power:	74.7 hp @ 1663 US gpm
--- Max Curve ---	
Max Power:	80.1 hp @ 1513 US gpm

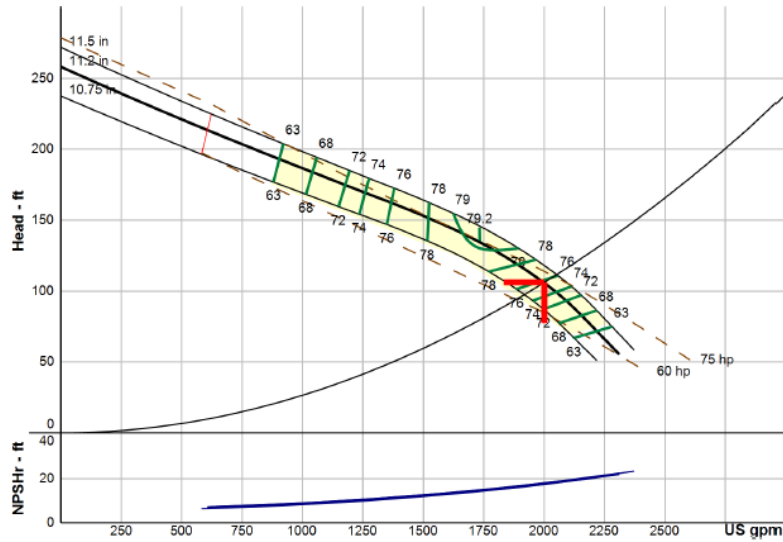

Nominal performance shall comply to ANSI/HI 14.6 2B/3B acceptance criteria and may be derated for materials of construction and/or specified acceptance grade. Consult factory. www.simflo.com / pump-flo@simflo.com

Performance Evaluation:						
Flow	Speed	Head	Efficiency	Power	NPSHr	
US gpm	rpm	ft	%	hp	ft	
2400	1750	---	---	---	---	
2000	1750	106	75.6	70.6	17.7	
1600	1750	145	78.6	74.7	13.3	
1200	1750	173	72.6	72.3	9.97	
800	1750	200	58.1	68.9	7.78	

9. PROPOSAL EVALUATION

Proposals will be received, publicly opened, and names and monetary proposals of each Offeror read aloud. Subsequently, proposals will be evaluated and ranked according to the selection criteria described in this RFP. Not later than 45 days following the date the proposals were opened, the City will complete the evaluation and ranking of each proposal. The City will select the Offeror whose proposal offers the best value for the City based on the selection criteria and the City's evaluation. The City will enter into contract negotiations with highest ranked offeror for award of a contract to complete the Project. If negotiations with highest ranked firm are unsuccessful, the City will formally close negotiations with that firm and negotiate with next highest ranked firm, and so on. Upon agreement and receipt of the Offeror's signature on the Standard Construction Contract, as contained in this RFP, the city council shall consider award of the contract to the Offeror and upon approval, Contract will be executed by Owner.

The entire RFP and all accompanying documentation should be considered when submitting a responsive proposal. Offerors have responsibility for the completeness and responsiveness of a proposal. The City reserves the right to reject or otherwise disqualify any Offeror whose proposal contains errors even if such errors arise from an Offeror's misinterpretation of the RFP and associated documents. Dates, locations, and times of the proposal submittal are outlined in the Advertisement for Proposal.

The City and Engineer, in making copies of Bid Documents available on above noted terms, do so only for purpose of obtaining Proposals for Work and do not confer a license or grant for any other use.

10. SELECTION CRITERIA

The City, through the city council, has delegated authority for evaluation and ranking of proposals to a sub-committee comprised of city council members and/or city staff. The sub-committee will evaluate each Offeror's proposal using the following criteria and weighting:

1. Project Cost: 50 points
Offeror's Proposed Cost of Performing Work shall be indicated in the Bid or Proposal Form.
2. Experience and reputation of Offeror & quality of Offeror's goods: 30 points
Provide general information about the corporate structure, organization, and professional history of Offeror including value of work under contract and bonding capacity. Organization and a Statement of Qualifications. Include information on Projects of similar size and type which Offeror has performed in the last five (5) years. This list is to include name and a current telephone number of references for each listed project. Offerors shall confirm the ability to procure and install the pre-approved materials as addressed in section 1 above. Offerors who cannot procure pre-approved material shall include information on proposed alternate materials with all information required for an as-equal evaluation per section 1.
3. Schedule Compliance: 10 points
Provide information showing Offeror's approach to scheduling, expected production rates, and processes to ensure schedule compliance. on Offeror's ability to devote adequate resources to the Project. If subcontractors will be utilized by Offeror, include information for schedule control applicable to subcontractors.
4. Other Factors: 10 points
Owner will consider other factors in evaluating Bids, including but not limited to the following:
 - a. The bidder's past relationship with the municipality.
 - b. Audited financial statement.
 - c. Safety: Demonstrated success in implementation of a site safety program.
 - d. Litigation History: Provide a list of all litigation, whether in court or arbitration, involving construction Projects in which Offeror has been a named party in the last five (5) years.

The criteria and weighting for the ranking of Offeror's Proposals is as outlined Below:

<u>Item No.</u>	<u>Evaluation Criteria</u>	<u>Points</u>
1.	Project Cost	50
2.	Experience & Reputation	30
3.	Schedule Compliance	10
4.	Other Factors	10
TOTAL		100

To permit the process of evaluation, ranking, and negotiation to occur as outlined in section 2 above, Offerors may not withdraw their Proposals for 90 calendar days from date on which Proposals are opened. If a submitted BID is withdrawn within the said period, BID guarantee shall become property of the OWNER, not as penalty, but as liquidated damages, and OWNER may pursue other action allowed by law.

Proposal Security of up to the five (5) highest-ranking firms will be held by Owner until contract negotiations are finalized. The successful Offeror, after city council approval of award, must furnish required bonds on forms provided with the Contract Documents. Performance and payment bonds shall be issued in an amount of one hundred percent (100%) of the contract amount from a solvent Surety company, authorized to do business in the State of Texas and acceptable to the OWNER. Prior to the City's final acceptance of the Work and payment of retainage, the selected Offeror shall issue the City a Maintenance Bond with a one-year term and a penal sum of ten (10) percent of the contract amount.

4. OTHER PROCEDURES

Owner may conduct such investigations as Owner deems necessary to assist in evaluation of any Proposal and to establish the responsibility, qualifications and financial ability of Offerors in accordance with information submitted with a proposal.

Owner, at its discretion, may also choose to conduct interviews with any/all of the Offerors. Failure to participate in the interview may result in disqualification. Should Owner choose to conduct interviews with top ranking Offerors, they will be notified of:

1. Time and place for interview.
2. Interview format and agenda.
3. Individuals that are expected to participate in the interview.

Owner reserves right to adopt most advantageous interpretation of Proposals submitted in case of ambiguity or lack of clearness in stating Proposal Prices, to reject any or all Proposals, and/or waive informalities.

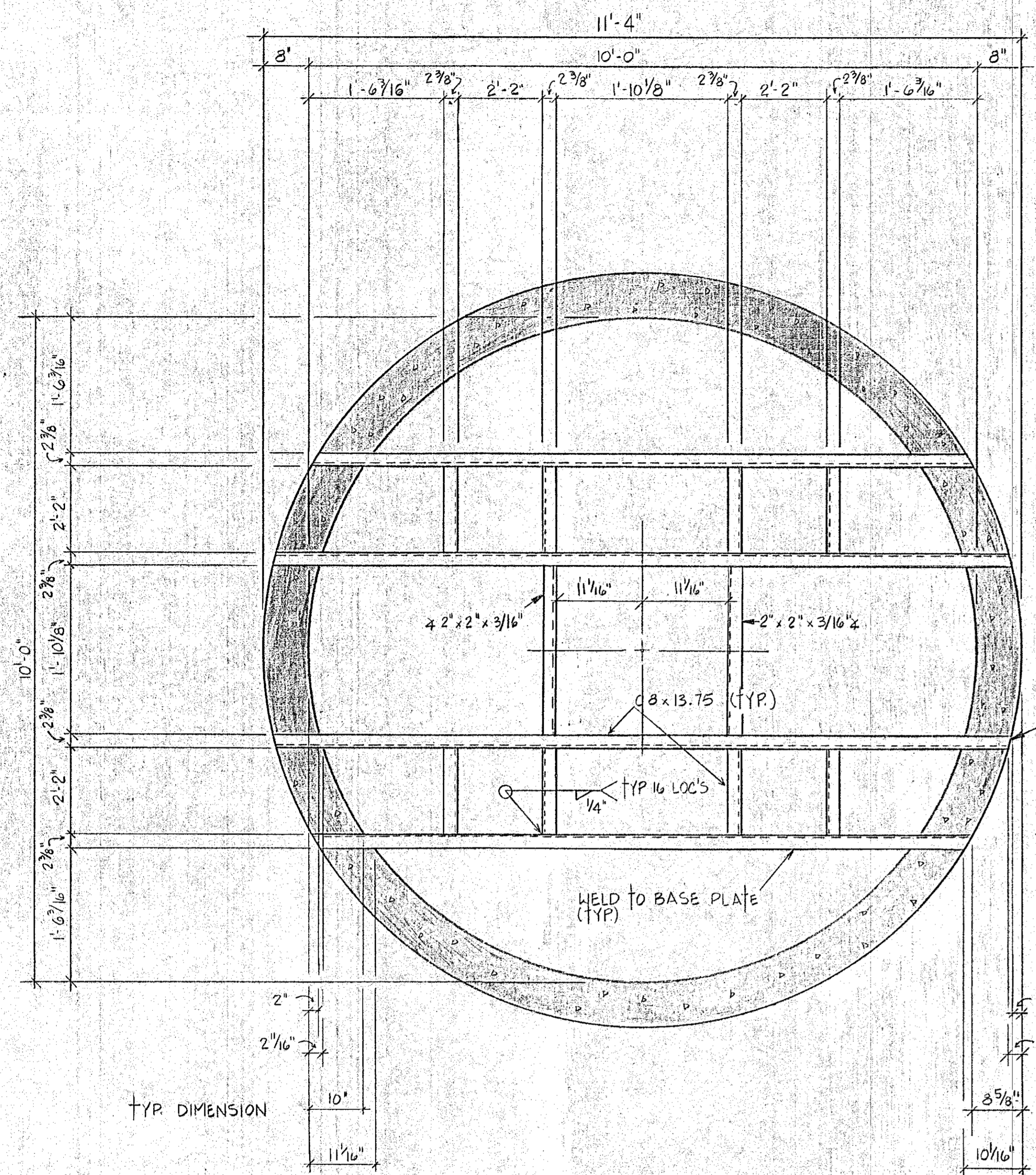

STRUCTURAL PLAN
WET WELL COVER
 3/4" = 1'-0"

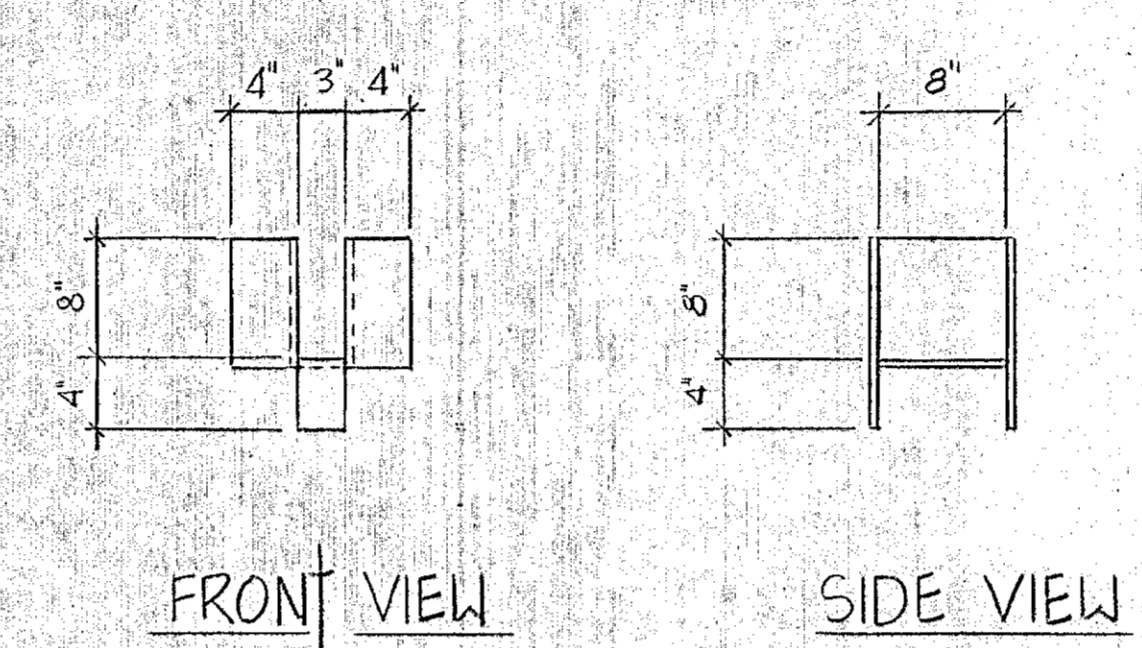
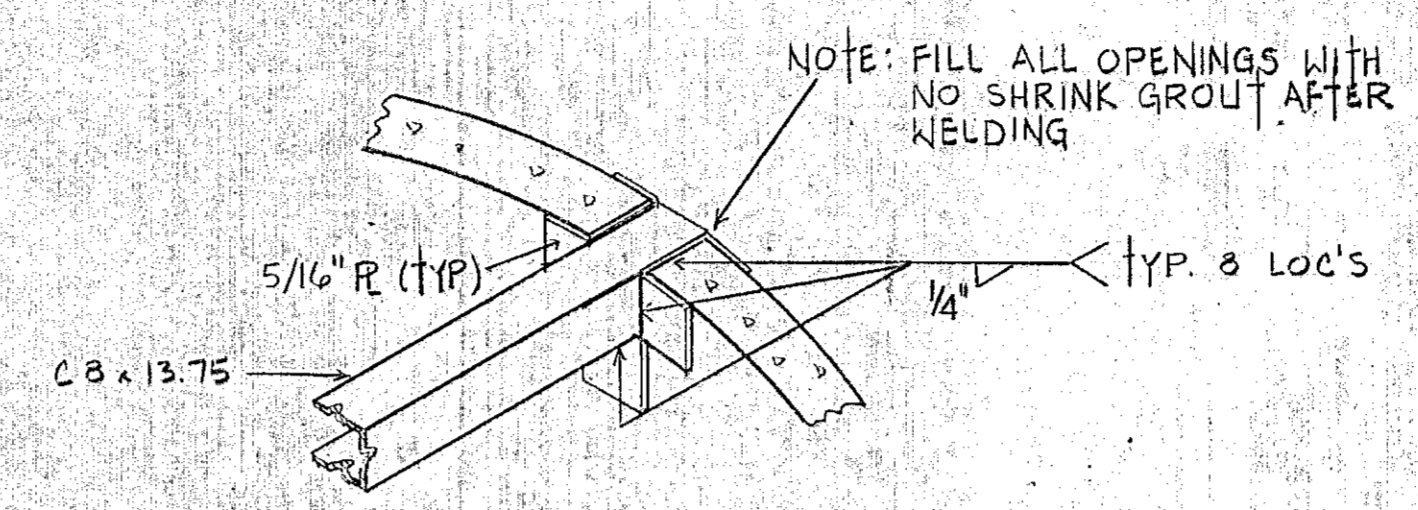

SUPPORT SADDLE

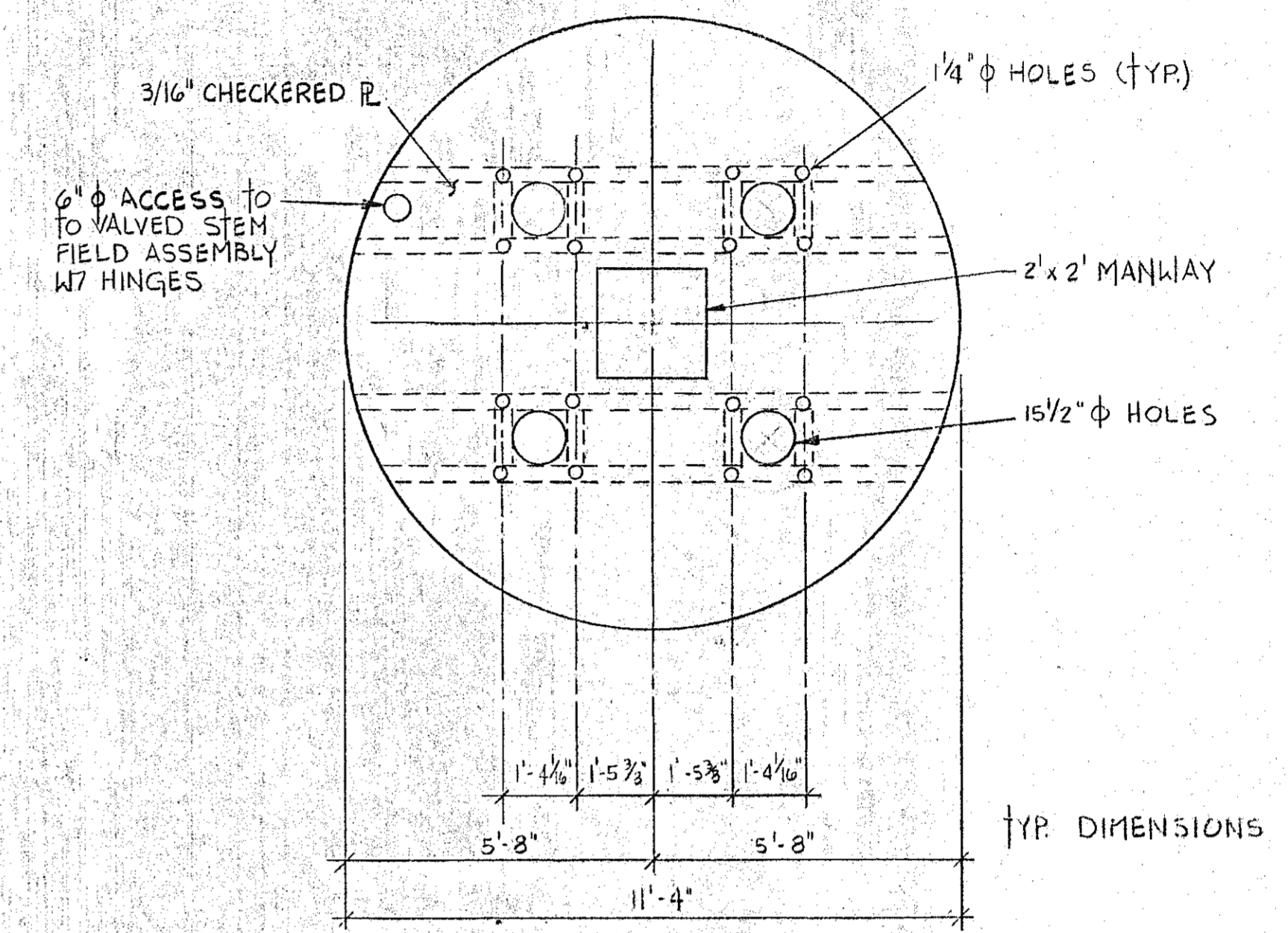

BOLT HOLE LOCATIONS

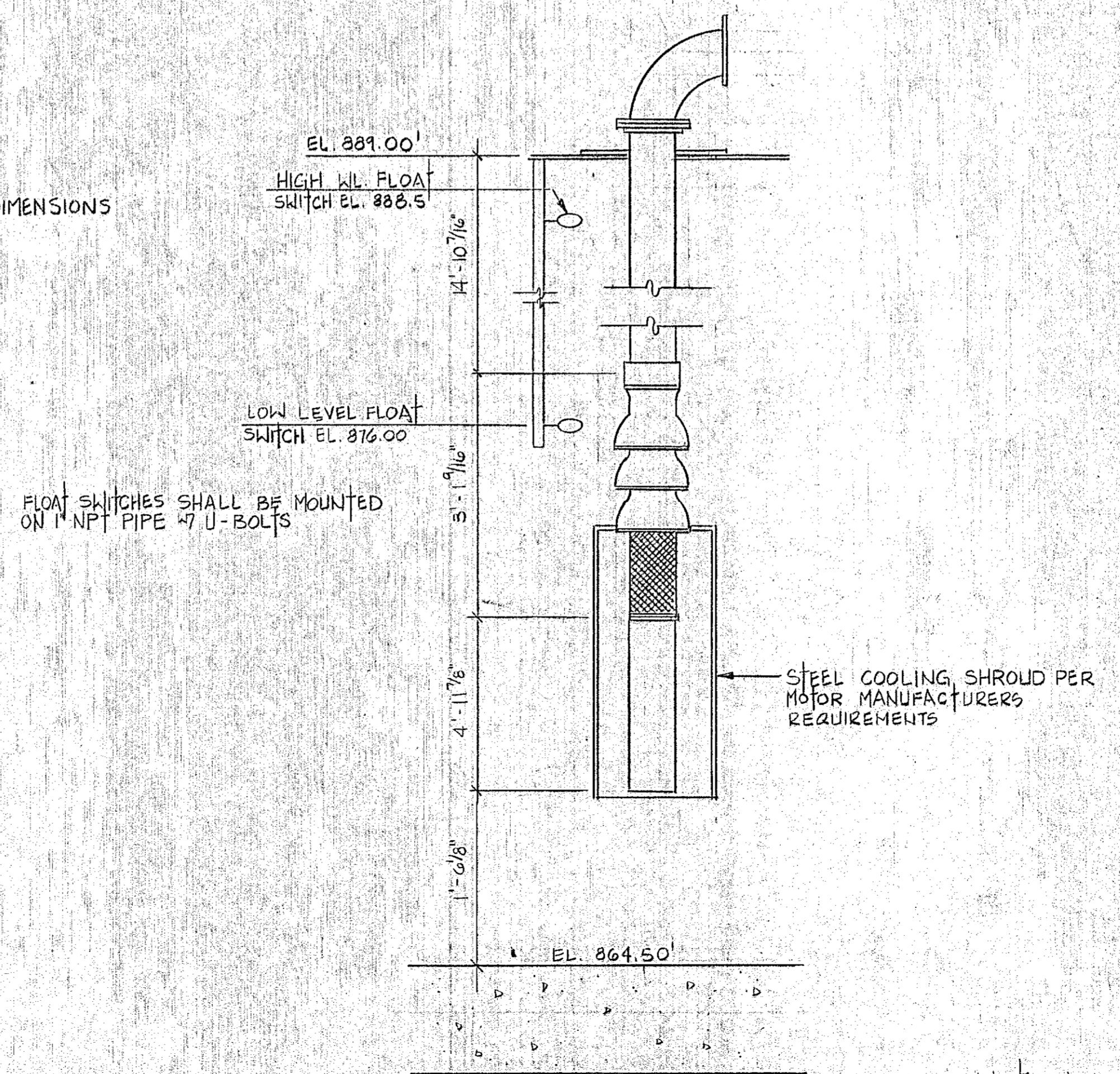

WET WELL DETAILS

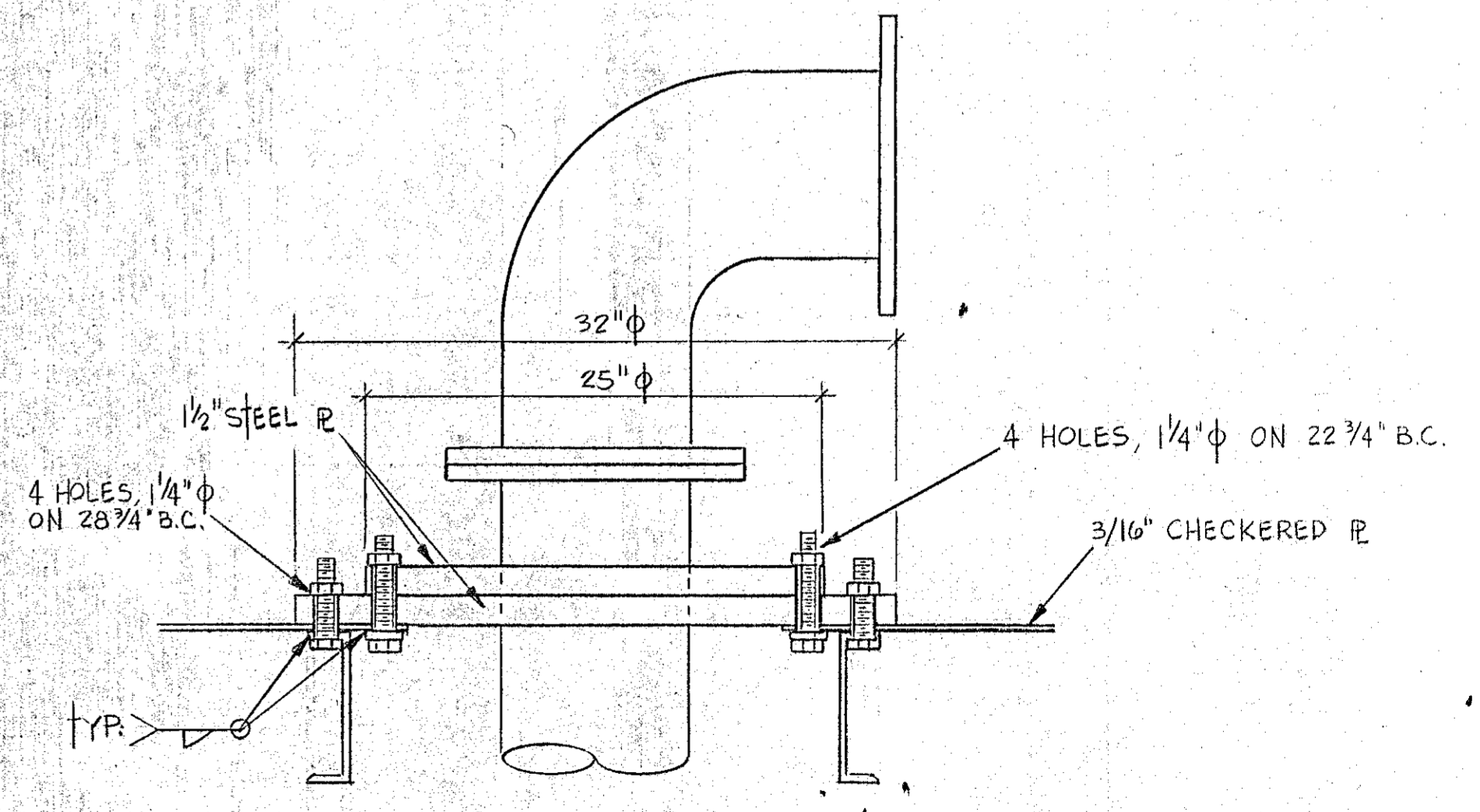

DISCHARGE HEAD

Certification of No Boycott

No Boycott Israel

If Contractor/Vendor is a "Company", as that term is defined in Section 808.001 of the Texas Government Code and is not a sole proprietorship, then Contractor/Vendor certifies and verifies that it: (i) does not boycott Israel and (ii) will not boycott Israel during the term of the Purchase Order or Contract this Certification is attached to and incorporated into; or (iii) that it meets the requirements of an exception listed below.

Form requirements:

- **This certification is required by Texas Government Code § 2271.002.**
- This form is required to be attached to and is incorporated into all Purchase Orders (goods) and Contracts (services) with a value of \$100,000 or more that is paid in whole or in part with state funds with a company with 10 or more full time employees. The campus department making the purchase of goods or contracting for services is responsible for obtaining the form from the Vendor or Contractor.

Texas Government Code §808.001 states that "Boycott Israel" means "refusing to deal with, terminating business activities with, or otherwise taking any action that is intended to penalize, inflict economic harm on, or limit commercial relations specifically with Israel, or with a person or entity doing business in Israel or in an Israeli-controlled territory, but does not include an action made for ordinary business purposes". Furthermore, Texas Government Code §808.001 states that the term "Company" means a "for-profit sole proprietorship, organization, association, corporation, partnership, joint venture, limited partnership, limited liability partnership, or limited liability company, including a wholly owned subsidiary, majority-owned subsidiary, parent company, or affiliate of those entities or business associations that exists to make a profit", provided however that Texas Government Code §2271.001(2) excludes sole proprietorships from this definition of "Company".

Vendor/Contractor Name or Company Name	
Street Address	
City	
State	
Zip Code	
Phone Number	
Printed Name of Authorized Representative	
Title of Authorized Representative	
Signature of Authorized Representative	
Date	

ONLY COMPLETE THIS SECTION IF YOU BELIEVE YOU ARE NOT REQUIRED TO PROVIDE THE CERTIFICATION - No Boycott Israel - FOR THE REASONS CITED BELOW

My business is not required to provide the certification listed above because (select one):

- My business is not a for-profit "Company" as defined above, pursuant to Texas Government Code §808.001 and §2271.001.
- My Company has less than 10 full-time employees
- This is not an agreement for goods or services to be provided to the City.

Name

Signature

Date

Certification of No Boycott

No Boycott Energy Company

If Contractor/Vendor is a "Company", as that term is defined in Section 809.001 of the Texas Government Code and is not a sole proprietorship, then Contractor/Vendor certifies and verifies that it: (i) does not boycott energy companies and (ii) will not boycott energy companies during the term of Purchase Order or Contract this Certification is attached to and incorporated into; or (iii) that it meets the requirements of an exception listed below.

Form requirements:

- **This certification is required by Texas Government Code § 2274.002.**
- This form is required to be attached to and is incorporated into all Purchase Orders (goods) and Contracts (services) with a value of \$100,000 or more that is paid in whole or in part with state funds with a company with 10 or more full time employees. The campus department making the purchase of goods or contracting for services is responsible for obtaining the form from the Vendor or Contractor.

Texas Government Code §809.001(1) states that "Boycott energy company" means "without an ordinary business purpose, refusing to deal with, terminating business activities with, or otherwise taking any action that is intended to penalize, inflict economic harm on, or limit commercial relations with a company because the company: (A) engages in the exploration, production, utilization, transportation, sale, or manufacturing of fossil fuel-based energy and does not commit or pledge to meet environmental standards beyond applicable federal and state law; or (B) does business with a company described by Paragraph (A)". Furthermore, Texas Government Code §809.001(2) states that the term "Company" means a "for-profit sole proprietorship, organization, association, corporation, partnership, joint venture, limited partnership, limited liability partnership, or limited liability company, including a wholly owned subsidiary, majority-owned subsidiary, parent company, or affiliate of those entities or business associations that exists to make a profit", provided however that Texas Government Code §2274.001(2) excludes sole proprietorships from this definition of "Company".

Vendor/Contractor Name or Company Name	
Street Address	
City	
State	
Zip Code	
Phone Number	
Printed Name of Authorized Representative	
Title of Authorized Representative	
Signature of Authorized Representative	
Date	

ONLY COMPLETE THIS SECTION IF YOU BELIEVE YOU ARE NOT REQUIRED TO PROVIDE THE CERTIFICATION – No Boycott Energy Company - FOR THE REASONS CITED BELOW

My business is not required to provide the certification listed above because (select one):

- My business is not a for-profit "Company" as defined above, pursuant to Texas Government Code §809.001(2) and §2274.001(2).
- My Company has less than 10 full-time employees
- This is not an agreement for goods or services to be provided to the City.

Name

Signature

Date

Certification of No Boycott

No Discrimination against Firearm and Ammunition Industries

If Contractor/Vendor is a “Company”, as that term is defined in Section 2274.001 of the Texas Government Code and is not a sole proprietorship, then Contractor/Vendor certifies and verifies that it: (i) does not have a practice, policy, guidance, or directive that discriminates against a firearm entity or firearm trade association and (ii) will not discriminate against a firearm entity or firearm trade association during the term of the Purchase Order or Contract this Certification is attached to and incorporated into; or (iii) that it meets the requirements of an exception listed below.

Form requirements:

- **This certification is required by Texas Government Code § 2274.002**
- This form is required to be attached to and is incorporated into all Purchase Orders (goods) and Contracts (services) with a value of \$100,000 or more that is paid in whole or in part with state funds with a company with 10 or more full time employees. The campus department making the purchase of goods or contracting for services is responsible for obtaining the form from the Vendor or Contractor.

Texas Government Code §2274.001(3) states that " discriminate against a firearm entity or firearm trade association " means “with respect to the entity or association, to: (i) refuse to engage in the trade of any goods or services with the entity or association based solely on its status as a firearm entity or firearm trade association; (ii) refrain from continuing an existing business relationship with the entity or association based solely on its status as a firearm entity or firearm trade association; or (iii) terminate an existing business relationship with the entity or association based solely on its status as a firearm entity or firearm trade association”. Furthermore, Texas Government Code §2274.001(2) states that the term “Company” means a “a for-profit organization, association, corporation, partnership, joint venture, limited partnership, limited liability partnership, or limited liability company, including a wholly owned subsidiary, majority-owned subsidiary, parent company, or affiliate of those entities or associations that exists to make a profit. The term does not include a sole proprietorship.”

Vendor/Contractor Name or Company Name	
Street Address	
City	
State	
Zip Code	
Phone Number	
Printed Name of Authorized Representative	
Title of Authorized Representative	
Signature of Authorized Representative	
Date	

ONLY COMPLETE THIS SECTION IF YOU BELIEVE YOU ARE NOT REQUIRED TO PROVIDE THE CERTIFICATION –No Discrimination against Firearm and Ammunition Industries- FOR THE REASONS CITED BELOW

My business is not required to provide the certification listed above because (select one):

- My business is not a for-profit “Company” as defined above, pursuant to Texas Government Code §2274.001(2).
- My Company has less than 10 full-time employees
- This is not an agreement for goods or services to be provided to the City.

Name

Signature

Date

SENATE BILL 252 – CHAPTER 2252 VERIFICATION

Effective September 1, 2017 contracts with companies engaged in business with Iran, Sudan, or foreign terrorist organization is prohibited. A governmental entity may not enter into a governmental contract with a company that is identified on a list prepared and maintained under Section 806.051, 807.051 or 2252.153. The comptroller shall prepare and maintain, and make available to each governmental entity, a list of companies known to have contracts with or provide supplies and services to a foreign terrorist organization.

I, _____, the undersigned representative of _____ (Company or Business Name) being an adult over the age of eighteen (18) years of age, pursuant to Texas Government Code, Chapter 2252, Section 2252.152 and Section 2252.153, certify that the company names above is not listed on the website of the Comptroller of the State of Texas concerning the listing of companies that are identified under Section 806.051, Section 807.051 or Section 2253.153.

I further certify that should the above-named company enter into a contract that is on said listing of companies on the website of the Comptroller of the State of Texas which do business with Iran, Sudan or any Foreign Terrorist Organization, I will immediately cause the work under contract with the City to stop, and notify the City of Burnet, office of the City Manager. I understand that any cost associated delays or cancellation of such work regarding this certification will not be compensated by the City. Furthermore, I understand that the City may consider this association as noted above, a breach of contract and may terminate the contract.

SIGNED: _____

DATE: _____

TITLE: _____